

Geoprobe® Model 6610DT

- Over 20 ton pulling capacity for today's larger sampling tools and deeper depths
- Equipped with the powerful GH62 Hammer
- Heavy Duty Undercarriage has a wider track that carries more weight, adds more torque, reduces ground pressure and handles greater tool weight
- Tethered remote control transmitter
- Built-in rotary spindle for concrete drilling, augering, and anchoring
- Equipped with a hydraulic winch for handling augers and tripping dual tube sampling tools
- Two-speed probe cylinder cycles from bottom to top in less than 5 seconds
- Hydraulic movement in all three axes allows easy probe alignment with tool string
- Auxiliary hydraulic ports provide power for remote equipment

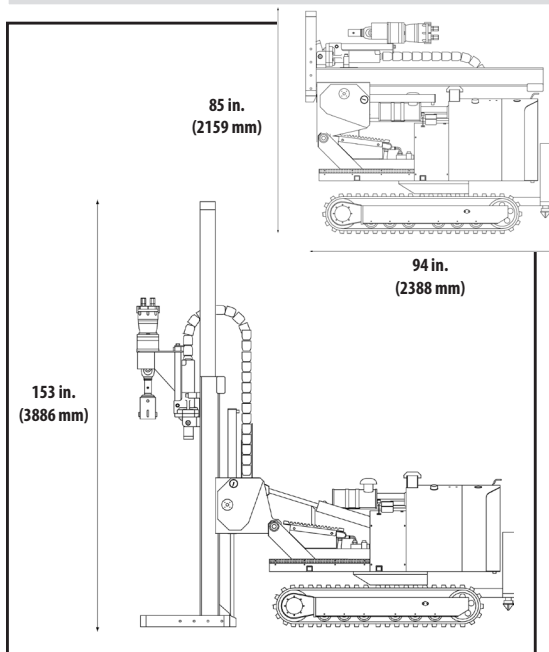

Geoprobe® GH62 Percussion Hammer & GA3000 Auger Head



Model 6610DT Specifications

Stroke.....	66 in.	1676 mm
Weight	5,700 lb.	2585 kg
Width	48 in.	1219 mm
Length (folded)	94 in.	2388 mm
Height (folded)	85 in.	2159 mm
Height (unfolded)	153 in.	3886 mm
Lateral Movement (side-to-side)	36 in.	914 mm
Foot Travel	39 in.	991 mm
Extension	15 in.	381 mm
Down Force	35,000 lb.	160 kN
Retraction Force	47,000 lb.	214 kN
Hydraulic Pressure (system)	2,450 psi	169 bar
Hydraulic Flow Rate (system)	30 gpm	114 Lpm
Hammer System	GH62	
Percussion Rate	32 Hz	
Torque (hammer motor)	560 ft. lb.	759 N-M
Rotation Rate (hammer motor)	240 rpm (bi-directional)	
Fuel Capacity (diesel)	15 gal	57 L
Engine (diesel)	Kubota, 4-cylinder turbo	
Engine Power	54 hp	40 Kw
Outrigger Extension	16 in.	406 mm
Travel Speed	0-2.5 mph.....	0-4 kph
Surface Load	4.3lb/in ²	0.3 kg/cm ²
Winch Rating	2,350 lb	1,067 kg
Winch Speed	0-110 fpm	0-33.5 m/min

Geoprobe Tooling Run with model 6610DT:

- Macro Core® MC5 Soil Sampling
- DT22 Soil Sampling
- DT325 Soil Sampling
- SP22 Groundwater Sampling
- SP16 Ground Water Sampling
- H S A Applications
- Prepack & Standard Monitoring Well Installations



6610DT Control Panel

Augerhead Specifications

Torque (high torque/low speed).....	3,000 ft. lb.	4067 N-M
Torque (low torque/high speed).....	1,500 ft. lb.	2034 N-M
Hex adapter.....	1-5/8 in.	41 mm
Rotation speed (low speed/high torque).....	0-105 rpm	
Rotation speed (high speed/low torque).....	0-150 rpm	

